

SIP SMT05-05

S E R I E S

5 AMP POL CONVERTERS

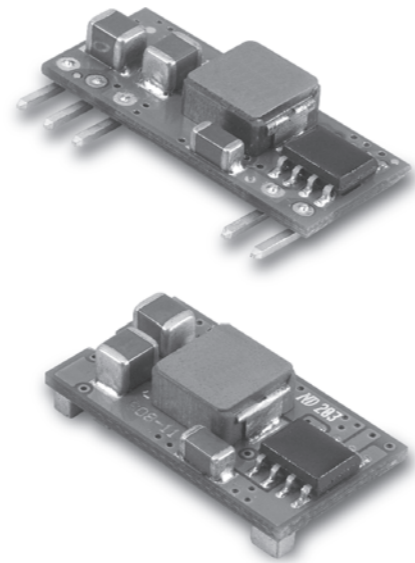

Features

- Non-Isolated POL Converter
- SIP / SMT Package
- Output Current 5AMP
- Input Voltage Range 3.0-5.5VDC
- Output Voltage Range 0.75-3.63VDC
- High Efficiency to 94%
- Over Temperature Protection
- Continuous Short Circuit Protection
- Remote On/Off Control
- UL/C-UL 60950 Certified

MODEL NUMBER	INPUT VOLTAGE	OUTPUT VOLTAGE	OUTPUT CURRENT	INPUT CURRENT		% EFF.
				NO LOAD	FULL LOAD	
SIP05-05S33A	3.0 - 5.5 VDC	0.75VDC	5 A	25mA	949mA	79
	3.0 - 5.5 VDC	1.2VDC	5 A	30mA	1412mA	85
	3.0 - 5.5 VDC	1.5VDC	5 A	30mA	1724mA	87
	3.0 - 5.5 VDC	1.8VDC	5 A	35mA	2022mA	89
SMT05-05S33A	3.0 - 5.5 VDC	2.0VDC	5 A	35mA	2222mA	90
	3.0 - 5.5 VDC	2.5VDC	5 A	35mA	2217mA	92
	3.0 - 5.5 VDC	3.0VDC	5 A	35mA	2217mA	92
	4.5 - 5.5 VDC	3.3VDC	5 A	35mA	3511mA	94

NOTE: 1. Nominal Input Voltage 5 VDC

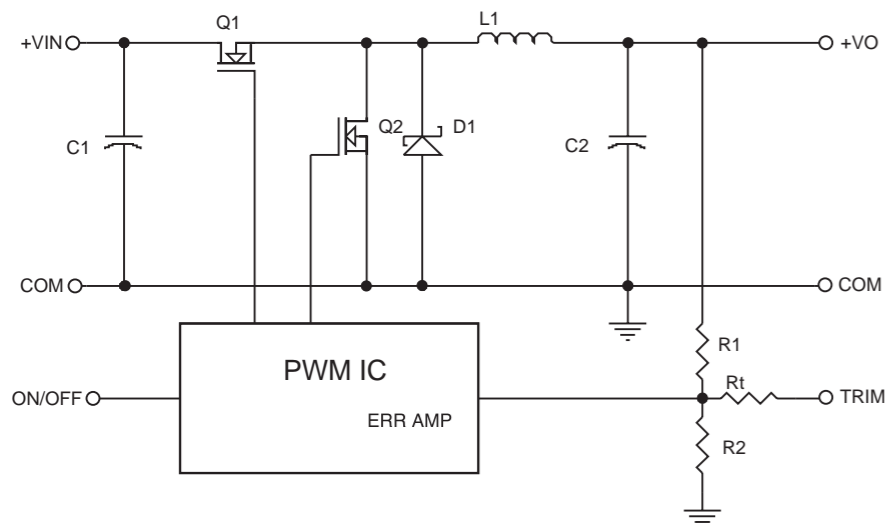

Figure 1. Simplified Schematic

Vo, set (V)	Rtrim (KΩ)
0.75	Open
1.2	41.71
1.5	22.98
1.8	14.96
2.0	11.75
2.5	6.93
3.3	3.15
3.63	2.20

Table 1. External Resistor Values for programming output voltage

Specifications

INPUT SPECIFICATIONS:
 Input Voltage Range..... $V_{o,set} \leq V_{in} - 0.5VDC$5V.....3.0 - 5.5V
 Under Voltage Lock-outPower up2.0V Typ.
 Power down.....1.9V Typ.

Input Filter Type.....Capacitive
 Positive Remote on/off Control :
 Module ON.....Open Circuit or = V_{in}
 Module OFF.....< 0.4 Vdc

OUTPUT SPECIFICATIONS:
 Voltage Accuracy.....±1.5% max.
 Transient Response :25% Step Load Change.....<200μ sec.
 Ripple and Noise, 20MHz BW³.....20mV rms max.
 50mV pk-pk max.
 Temperature Coefficient.....±0.03%/C max.
 Short Circuit Protection.....Continuous
 Line Regulation¹.....± 0.4% max.
 Load Regulation².....± 0.5% max.
 Capacitive Load, Low ESR.....3000μF max.
 External Trim Adj. Range (see Table 1)..... $V_o=0.75-3.63VDC$

GENERAL SPECIFICATIONS:
 Efficiency.....See Table
 Isolation Voltage.....Non-isolation
 Switching Frequency300KHz Typ.
 Over Temperature Protection120°C Typ.
 Operating Ambient Temperature Range.....-40°C to +85°C
 Power Derating Curvesee Figure 2,3
 Storage Temperature Range-55°C to +125°C
 Dimensions:
 SIP Package: 0.90 x 0.400 x 0.22 inches (22.9 x 10.16 x 5.6 mm)
 SMT Package: 0.80 x 0.450 x 0.24 inches (20.3 x 11.43 x 6.09 mm)
 Structure.....Non-potted With Open Frame Type
 Weight.....2.3g

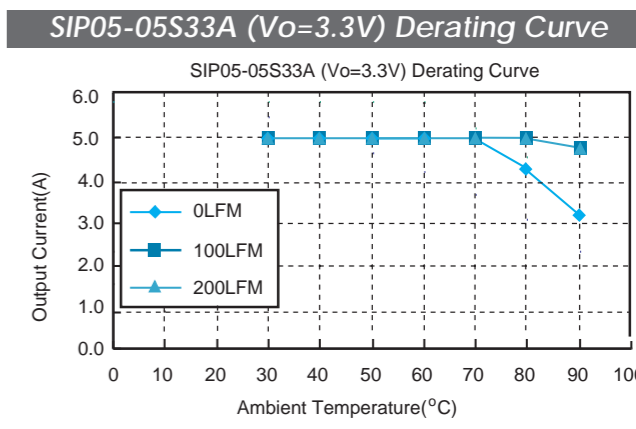

Figure 2. Typical Power De-rating for 5V IN 3.3Vout

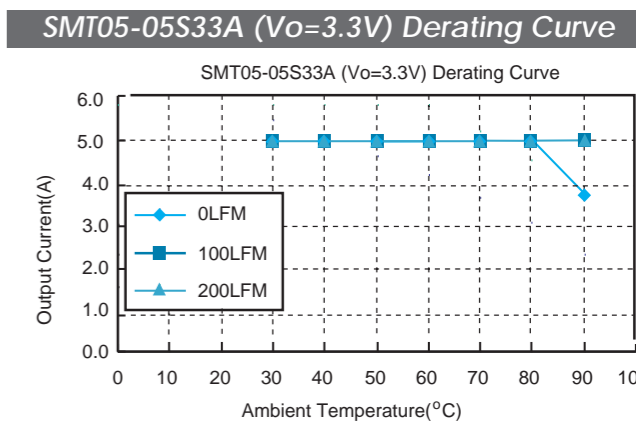

Figure 3. Typical Power De-rating for 5V IN 3.3Vout

NOTE:

1. Measured From High Line to Low Line, $V_{o,set}=1.8Vdc$
2. Measured From Full Load to Zero Load, $V_{o,set}=3.3Vdc$
3. The output noise is measured with 10μf tantalum capacitor and 1μf ceramic capacitor across output.
4. The Input Terminal Recommend to Parallel With 100μF Capacitor ESR<100mΩ to Reduce The Input Ripple Voltage
5. Suffix "N" to the Model Number with Negative Logic Remote on/off
 Model ON.....Open Circuit or < 0.4VDC
 Module OFF.....>+2.8VDC to V_{in}

Mechanical Specification

All Dimensions In Inches(mm)
 Tolerance Inches: x.xx= ±0.02, x.xxx= ±0.010
 Millimeters: x.x= ±0.5, x.xx= ±0.25

SIP Packages

SMT Packages

PIN CONNECTION

Pin	Function
1	+Output
2	Trim
3	Common
4	+V Input
5	On/Off

1.1mm PLATED THROUGH HOLE
 1.6mm PAD SIZE

All Specifications Typical At Nominal Line, Full Load and 25°C Unless Otherwise Noted.

SIP SMT05-05